

IR.T SERIES CURRENT CONTROL RELAY

UL listed CSA recognized

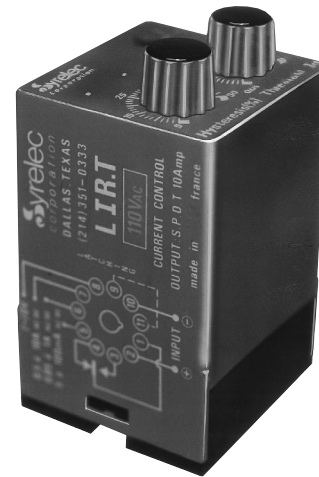

- Automatic or Manual Control
- Start-up Inhibit
- Adjustable Hysteresis
- Multiple Voltages
- LED Relay Status Indicator

1. AC Current Control Without Latching:

The output relay is energized when the current (peak current on AC) overshoots the level selected on the potentiometer. It de-energizes when the current falls below the normal current by 5 to 50% or when input power breaks. The hysteresis is controlled by a top mounted potentiometer and its selection does not change the chosen current level.

2. AC Current Control With Latching:

The output relay is energized when the current reaches the selected value and stays latched. The contact between terminal B1 and B2 (or 11 and 9) should be opened or input power to the device interrupted to reset. In this case, it is preferable to reduce the hysteresis 5%.

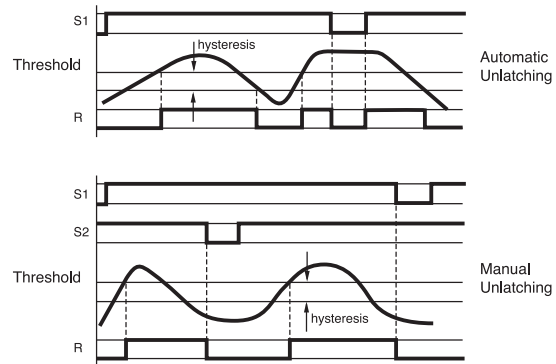

SPECIFICATIONS:

Input 24 VDC, 24, 48, 110, 220 VAC
±15%, 50/60 Hz

Power consumption 3 VA maximum

CONTROL RANGE		INPUT RESISTANCE	PERMITTED PERMANENTLY	OVERLOAD LESS THAN 1 sec Peak
DC CURRENT	AC CURRENT			
5 to 100 mA	3.5 to 70.7 mA	1 ohm	1.5 V	5 A
0.05 to 1 A	0.035 to 0.707 A	0.1 ohm	5 A	17 A
0.5 to 10 A	0.35 to 7.07 A	0.01 ohm	15 A	55 A

Hysteresis selection 5 to 50% of input current

Repeat accuracy ±2% at a constant ambient

Response time 100 ms On Make
200 ms On Break

Output Relay SPDT Relay

Contact material AgCdO

Maximum loading 10 A AC resistive 1 A DC inductive

Maximum switching voltage 250 VAC or DC

Relay maximum power rating 2500 VA 30W

Mechanical life of relay 30 x 10⁴ operations

Electrical life of relay 2 x 10⁵ at 2500 VA resistive load

Operating temperature +14°F to +140°F -10°C to +60°C

Weight 7 oz. (200g)

Option: 24 VDC power - the voltage and the measured current must be from separate sources.

Note: It is recommended that the unit be adequately fused.

WIRING DIAGRAM:

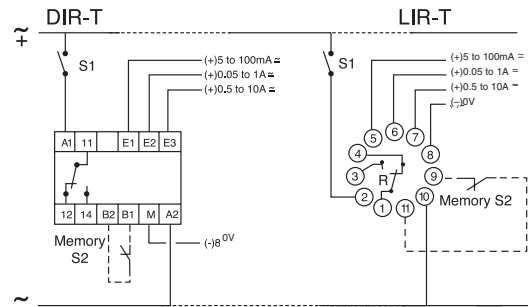

Note: Upon energization of the current control IR.T Series Relay, the time delay, which is adjustable from .1 to 10 seconds, inhibits the output relay during start-up periods. The delay time is adjustable via a potentiometer located on the side of the case. Applies to both versions, with and without latching.

ORDERING INFORMATION:

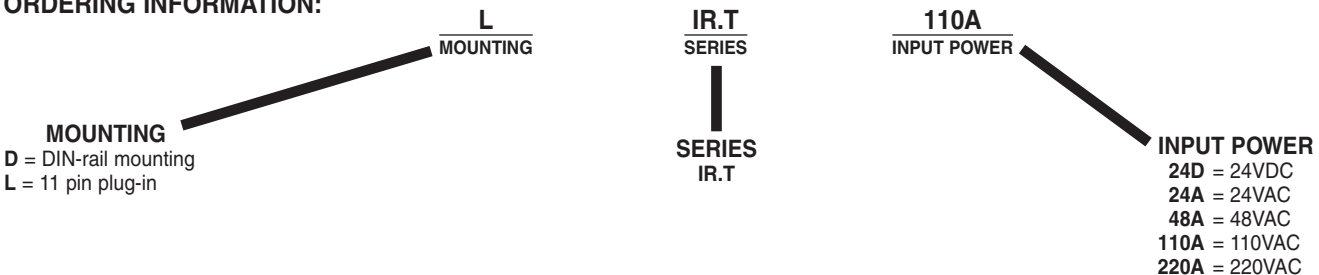

Products and specifications subject to change without notice.

Order/Technical Support – Tel: (800) 677-5311 / FAX: (800) 677-3865 / www.crouzet-usa.com